

# POWERFLEX®

## PART NUMBER

# PFR57-507

## DESCRIPTION

## REAR LOWER LINK ARM INNER BUSH

## INSTALLATION GUIDE

### Contents (parts per pack):

4 x Polyurethane Bushes      2 x Mild Steel Zinc Plated Washers  
2 x Stainless Steel Sleeves      1 x PTFE/Silicone Grease

Please read the complete fitting instructions and check package components before fitment. These fitting instructions are to be used as a guide and in conjunction with workshop manual.

It is recommended that:

- all work to be carried out by a licensed technician;
- all safety precautions adhered to;
- wheel alignment to be checked and adjusted as required after any suspension work.
- All fasteners must be tensioned to manufacturer's torque settings.

### Fitting Instructions:

1. Remove the original bush from the control arm.
2. Clean any dirt and corrosion from the bore of the arm, removing any sharp edges with a rounded file.
3. Insert the polyurethane bushes into the arm from either side.
4. Apply some of the supplied PTFE/Silicone grease to the bore of the bush and press the stainless steel sleeve in until flush.
5. Apply the rest of the grease to the end faces of the bush and fit the supplied steel D-shaped washers over the end of the sleeve.
6. Refit the arm into the subframe, ensuring the flat face of each D-shaped washer faces inwards. This provides clearance from the raised casting on the subframe, allowing a full adjustment range during alignment.
7. Reinstall the mounting bolt and make any necessary tracking adjustments.
8. Tighten all hardware to the manufacturer's recommended torque specification..

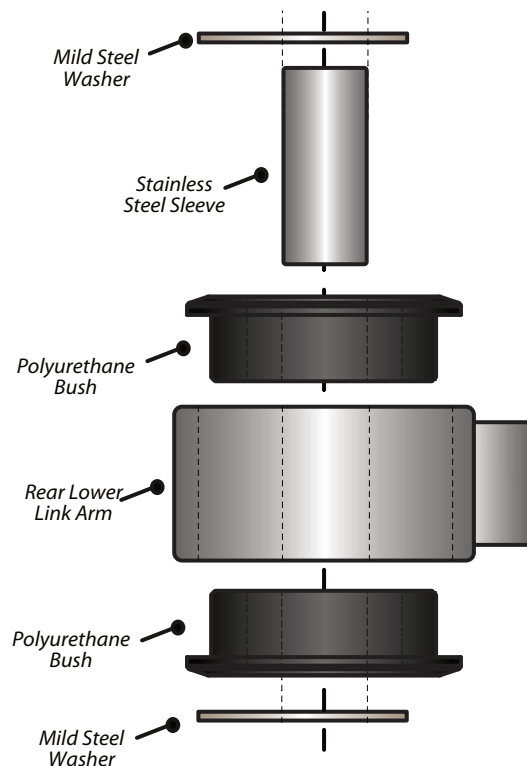

Figure 1